

Go to [www.vtechphones.com](http://www.vtechphones.com) to register your product for enhanced warranty support and the latest VTech product news.

DECT 6.0 cordless telephone

CS6829  
CS6829-2  
CS6829-26  
CS6829-3



# vtech

## Abridged user's manual

### Congratulations

on purchasing your new VTech product. Before using this telephone, please read **Important safety instructions**.

This abridged user's manual provides you with basic installation and use instructions. A limited set of features are described in abbreviated form.

Please refer to the user's manual for a full set of installation and operation instructions at [www.vtechphones.com](http://www.vtechphones.com).



Telephones identified with this logo have reduced noise and interference when used with most T-coil equipped hearing aids and cochlear implants. The TIA-1083 Compliant Logo is a trademark of the Telecommunications Industry Association. Used under license.

### What's in the box

Your telephone package contains the following items. Save your sales receipt and original packaging in the event warranty service is necessary.

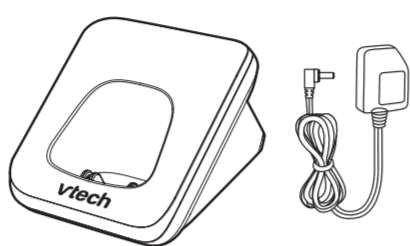
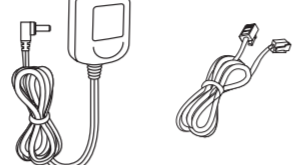
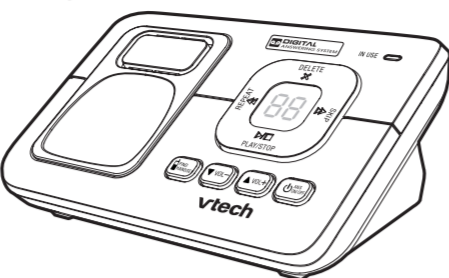

1 set for CS6829-2/CS6829-26;  
2 sets for CS6829-3



1 set for CS6829;  
2 sets for CS6829-2/CS6829-26;  
3 sets for CS6829-3

### Telephone base overview

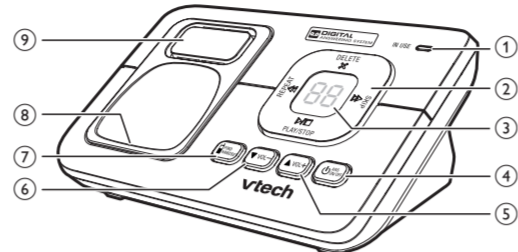

- IN USE light**
  - Flashes when there is an incoming call, or another telephone sharing the same line is in use.
  - Flashes when handsets are being deregistered.
  - On when the telephone is in use, or the answering system is answering a call.
  - On when a handset is being registered.
- Control key panel**
  - DELETE**
    - Delete the playing message.
    - Press twice to delete all old messages.
  - REPEAT**
    - Repeat a message.
    - Press twice to play the previous message.
  - SKIP**
    - Skip to the next message.
  - PLAY/STOP**
    - Play messages.
    - Stop playing messages.
- Message window**
  - Shows the number of messages, and other information of the answering system or telephone base.
- ANS ON/OFF**
  - Turn on or off the answering system.
- VOL+**
  - Increase the listening volume.
  - Increase the telephone base ringer volume.

### Telephone operations

Handset control key panel:

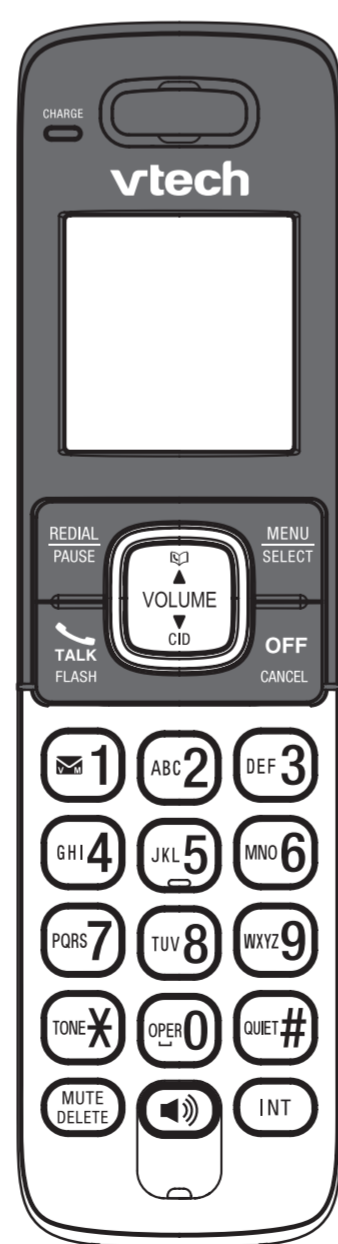

### 6 - VOL-

- Decrease the listening volume.
- Decrease the telephone base ringer volume.

### 7 - MUTE

- Page all system handsets.

### 8 - Charging pole

### 9 - Speakerphone

### Handset overview

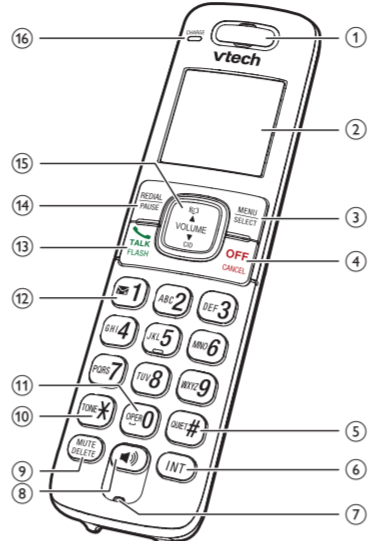

- Handset earpiece**
- LCD display**
- SELECT**
  - Show the menu.
  - While in a menu, press to select an item, or save an entry or setting.
- OFF**
  - Hang up a call.
  - Return to the previous menu or idle mode without making changes.
  - Delete digits while predialing.
  - Silence the handset ringer temporarily while the phone is ringing.
  - Erase the missed call indicator while the handset is not in use.
- QUIET #**
  - Turn on or off the quiet mode.
  - Show other dialing options when reviewing a caller ID log entry.
- INT**
  - Start an intercom conversation or transfer a call (for multi-handset models only).
- Microphone**

### Charger overview

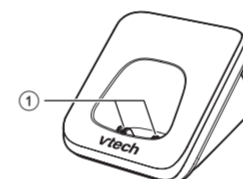

- Charging pole**

### Find handset

Use this feature to find the system handset.

#### To start paging:

- Press **FIND HANDSET** on the telephone base when not in use. All idle handsets ring and display **\*\* Paging \*\***.

#### To end paging:

- Press **FIND HANDSET** at the telephone base.
- OR** Press **VOLUME** or any of the dialing keys on the handset.
- OR** Place the handset in the telephone base or charger.

#### NOTE

- Do not press and hold **FIND HANDSET** for more than four seconds. It may lead to handset deregistration.

### Redial list

Each handset stores the last 10 telephone numbers dialed. When there are already 10 entries, the oldest entry is deleted to make room for the new entry.

#### Review and dial a redial list entry

- Press **REDIAL** when the handset is not in use.
- Press **VOLUME** or **REDIAL** repeatedly until the desired entry displays.
- Press **VOLUME** or any of the dialing keys to dial.

#### Delete a redial list entry

- When the desired redial entry displays, press **DELETE**.

### Intercom

Use the intercom feature for conversations between two handsets.

- Press **INT** on your handset when not in use. Use the dialing keys to enter a destination handset if necessary.
- To answer the intercom call, press **VOLUME**, **INT** or any dialing key on the destination handset.
- To end the intercom call, press **OFF** or place the handset back in the telephone base or charger.

#### Transfer a call (for multiple handset models only)

While on an outside call, you can transfer the call from one handset to another.

- During a call, press **MENU**.
- Press **VOLUME** or **▲** to choose **Transfer** and then press **SELECT**.
- To answer on the destination handset, press **VOLUME**, **▲** or any dialing key on the destination handset.

### Display icons overview

	The battery icon flashes when the battery is low and needs charging.
	The battery icon animates when the battery is charging.
	The battery icon becomes solid when the battery is fully charged.
	The handset ringer is turned off.
	There are new voicemail received from your telephone service provider.
<b>NEW</b>	There are new caller ID log entries.
<b>ANS ON</b>	The answering system is turned on.
	The message number currently playing and total number of new/old messages recorded.
<b>ECO</b>	The ECO mode activates automatically to reduce power consumption whenever the handset is synchronized with the telephone base.

### Telephone base lights overview

<b>IN USE</b>	<ul style="list-style-type: none"> <li>On when the telephone line is in use.</li> <li>On when the answering system is answering a call.</li> <li>On when you are registering a handset.</li> <li>Flashes quickly when there is an incoming call.</li> <li>Flashes when another telephone sharing the same line is in use.</li> <li>Flashes when you are deregistering all handsets.</li> </ul>
	On when the answering system is turned on.

### Handset lights overview

	On when the handset speakerphone is in use.
<b>CHARGE</b>	On when the handset is charging in the telephone base or charger.

### Connect

You can choose to connect the telephone base for desktop usage or wall mounting.

#### NOTES

- Use only the adapters provided.
- Make sure the electrical outlets are not controlled by wall switches.
- The adapters are intended to be correctly oriented in a vertical or floor mount position. The prongs are not designed to hold the plug in place if it is plugged into a ceiling, under-the-table or cabinet outlet.

#### TIP

- If you subscribe to digital subscriber line (DSL) high-speed Internet service through your telephone line, make sure you install a **DSL filter** (not included) between the telephone line cord and telephone wall jack. Contact your DSL service provider for more information.

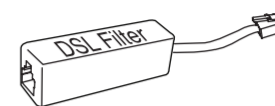

#### Connect the telephone base

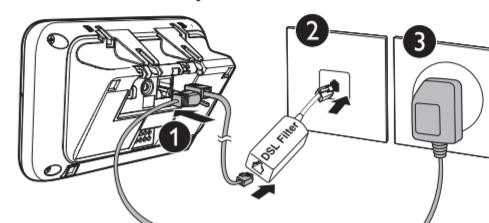

#### Connect the charger

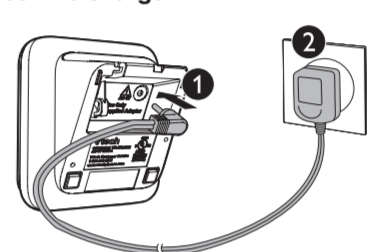

### Mount the telephone base

- Connect the telephone line cord to the telephone base. Route it through the wall mount bracket, and then connect it to the wall jack.

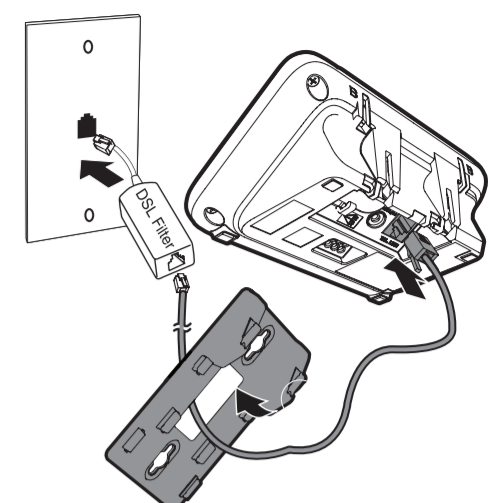

- Align and place the wall mount bracket on the standard wall plate.

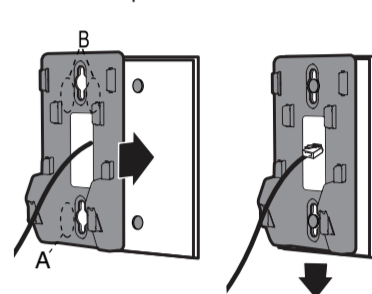

- Align and place the telephone base on the wall mount bracket.

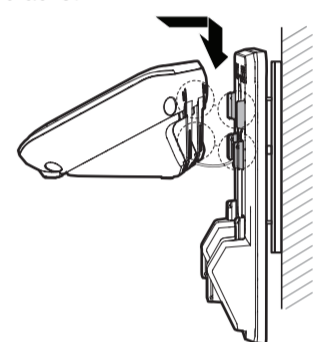

- Connect the power adapter.

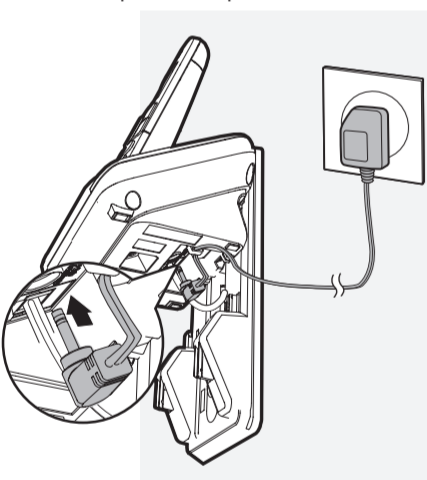

### Charge the battery

Place the handset in the telephone base or the charger to charge.



Once you have installed the battery, the handset LCD display indicates the battery status (see the table below).

- For best performance, keep the handset in the telephone base or charger when not in use.
- The battery is fully charged after 16 hours of continuous charging.
- If you place the handset in the telephone base or the charger without plugging in the battery, the screen displays **No battery**.

Battery indicators	Battery status	Action
The screen is blank, or displays <b>Put in charger</b> and	The battery has no or very little charge. The handset cannot be used.	Charge without interruption (at least 30 minutes).
The screen displays <b>Low battery</b> and	The battery has enough charge to be used for a short time.	Charge without interruption (about 30 minutes).
The screen displays <b>HANDSET X</b> .	The battery is charged.	To keep the battery charged, place it in the telephone base or charger when not in use.

### Before use

After you install your telephone or power returns following a power outage, the handset will prompt you to set the date and time.

#### Set date and time

- Make sure you set the date and time including the year correctly; otherwise the answering system does not announce the correct day of the week for your recorded messages time stamp.

- Use the dialing keys (0-9) to enter the month (MM), date (DD) and year (YY). Then press **SELECT**.
- Use the dialing keys (0-9) to enter the hour (HH) and minute (MM). Then press **VOLUME** or **▲** to choose **AM** or **PM**.
- Press **SELECT** to save.

#### Check for dial tone

Press **VOLUME**. If you hear a dial tone, the installation is successful.

If you do not hear a dial tone:

- Make sure the installation procedures described above are properly done.
- It may be a wiring problem. If you have changed your telephone service to digital service from a cable company or a VoIP service provider, the telephone line may need to be rewired to allow all existing telephone jacks to work. Contact your cable/VoIP service provider for more information.

### Operating range

This cordless telephone operates with the maximum power allowed by the Federal Communications Commission (FCC). Even so, this handset and telephone base can communicate over only a certain distance - which can vary with the locations of the telephone base and handset, the weather, and the layout of your home or office.

When the handset is out of range, the handset displays **Out of range** or **no pwr at base**.

If there is a call while the handset is out of range, it may not ring, or if it does ring, the call may not connect well when you press **VOLUME**. Move closer to the telephone base, then press **VOLUME** to answer the call.

If the handset moves out of range during a telephone conversation, there may be interference. To improve reception, move closer to the telephone base.

### Use the handset menu

- Press **MENU** when the phone is not in use.
- Press **VOLUME** or **▲** until the screen displays the desired feature menu.
- Press **SELECT**.
  - To return to the previous menu, press **CANCEL**.
  - To return to idle mode, press and hold **CANCEL**.

### Configure your telephone

#### Set language

The LCD language is preset to English. You can select English, French or Spanish to be used in all screen displays.

- Press **MENU** when the handset is not in use.
- Scroll to **Settings**, then press **SELECT** twice.
- Scroll to choose **English**, **Français** or **Español**.
- Press **SELECT** twice to save your setting.

#### Set date and time

- Make sure you set the date and time including the year correctly; otherwise the answering system does not announce the correct day of the week for your recorded messages time stamp.

- Press **MENU** on the handset when not in use.
- Scroll to **Set date/time** and then press **SELECT**.
- Use the dialing keys (0-9) to enter the month (MM), date (DD) and year (YY). Then press **SELECT**.
- Use the dialing keys (0-9) to enter the hour (HH) and minute (MM). Then press **VOLUME** or **▲** to choose **AM** or **PM**.
- Press **SELECT**.

#### Temporary tone dialing

If you have pulse (rotary) service only, you can switch from pulse to touch-tone dialing temporarily during a call.

- During a call, press **TONEX**.
- Use the dialing keys to enter the relevant number. The telephone sends touch-tone signals. It automatically returns to pulse dialing mode after you end the call.

### Install and charge the battery

#### Install the battery

Install the battery as shown below.

#### NOTES

- Use only supplied battery.
- Charge the battery provided with this product only in accordance with the instructions and limitations specified in this manual.
- If the handset will not be used for a long time, disconnect and remove the battery to prevent possible leakage.

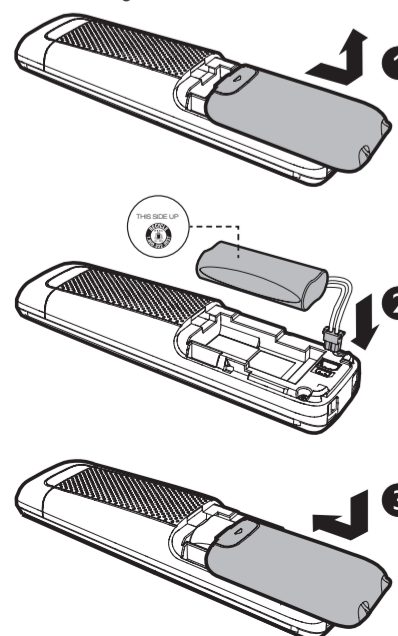

### Caller ID

If you subscribe to caller ID service, information about each caller appears after the first or second ring. If you answer a call before the caller information appears on the screen, it will not be saved in the caller ID log.

The caller ID log stores up to 50 entries. Each entry has up to 24 digits for the phone number and 15 characters for the name.

If the telephone number has more than 15 digits, only the last 15 digits appear. If the name has more than 15 characters, only the first 15 characters are shown and saved in the caller ID log.

#### Review a caller ID log entry

- Press **CID** when the phone is not in use.
- Scroll to browse through the caller ID log.

#### Missed call indicator

When there are calls that have not been reviewed in the caller ID log, the handset displays **XX missed calls**.

Each time you review a caller ID log entry marked **NEW**, the number of missed calls decreases by one.

When you have reviewed all the missed calls, the missed call indicator no longer displays.

If you do not want to review the missed calls one by one, press and hold **CANCEL** on the idle handset to erase the missed call indicator. All the entries are then considered old.

#### Dial a caller ID log entry

- When the desired entry appears, press **VOLUME**, **▲** to dial.

#### Save a caller ID log entry to the directory

- When the desired caller ID log entry displays, press **SELECT**.
- Use the dialing keys to modify the number, if necessary. Then press **SELECT**.
- Use the dialing keys to modify the name, if necessary. Then press **SELECT**.

#### Delete the caller ID log entries

- When the desired caller ID log entry displays, press **DELETE**.

To delete all caller ID log entries:

- Press **MENU** when the phone is not in use.
- Scroll to **Caller ID log** and then press **SELECT**.
- Scroll to **Del all calls** then press **SELECT** twice.

Handset control key panel:

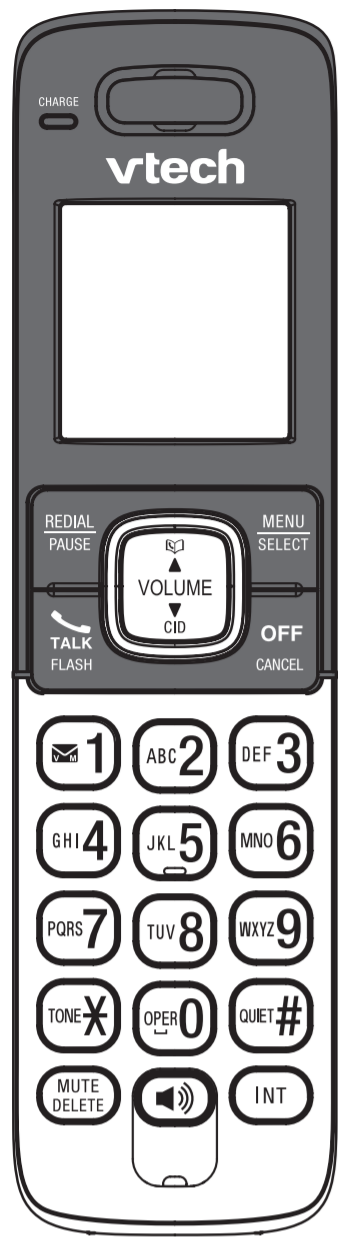

## Sound settings

### Quiet mode

You can turn on the quiet mode for a period of time. During this period, all tones (except paging tone) are muted. When you turn on the quiet mode, the answering system turns on automatically.

- Press and hold **QUIET** when the handset is not in use.
- Use the dialing keys **(0-9)** to enter the duration (hour), then press **SELECT** to save.
- To turn off the quiet mode, press and hold **QUIET** on the handset when the phone is not in use.

### Key tone

You can turn the key tone on or off.

- Press **MENU** when the handset is not in use.
- Scroll to **Settings** and then press **SELECT**.
- Scroll to choose **Key tone**, then press **SELECT**.
- Press **▼** or **▲** to choose **Key tone:On** or **Key tone: Off**, then press **SELECT** to save.

### Ringer tone

You can choose from different ringer tones for each handset.

- Press **MENU** when the handset is not in use.
- Scroll to **Ringers** and then press **SELECT**.
- Scroll to choose **Ringer tone**, then press **SELECT**.
- Press **▼** or **▲** to sample each ringer tone, then press **SELECT** to save.

#### NOTE

- If you turn off the ringer volume, you will not hear ringer tone samples.

### Telephone base ringer volume

Press **▲/VOL+** or **▼VOL-** on the telephone base to adjust the ringer volume when the telephone base is not in use.

When you set the ringer volume to zero, the base ringer is off. The telephone base announces, *"Base ringer is off."*

### Handset ringer volume

You can adjust the handset ringer volume level, or turn the ringer off.

- Press **MENU** when the handset is not in use.
- Scroll to **Ringers** and then press **SELECT** twice.
- Press **▼** or **▲** to sample each volume level, then press **SELECT** to save.

#### NOTE

- When the ringer volume is set to Off, the handset still rings when you press **#/FIND HANDSET** at the telephone base.

### Temporary ringer silencing

When the telephone is ringing, you can temporarily silence the ringer without disconnecting the call. The next call rings normally at the preset volume.

To silence the handset ringer:

- Press **OFF** or **MUTE**. The handset displays **☒** and **Ringer muted**.

To silence the telephone base ringer:

- Press **▼VOL-**.

## About the built-in answering system and voicemail service

For message recording, your telephone has a built-in answering system, and it also supports voicemail service offered by your telephone service provider (subscription is required, and fee may apply).

The main differences between them are:

Category	Built-in answering system	Voicemail from telephone service
Storage	Messages are stored in the telephone base.	Messages are stored in a server or system provided by your telephone service provider.
	Your messages will not be deleted automatically. You have to delete your messages manually.	Your messages may be automatically deleted after a period of time. Contact your telephone service provider for more details.
Method to retrieve messages	When you received new messages, the handset displays <b>XX new messages</b> and <b>CD</b> , and the message window on the telephone base flashes.	When you received new messages, the handset displays <b>☒</b> and <b>New voicemail</b> .
Method to retrieve messages	To retrieve messages, usually there are two ways: <ul style="list-style-type: none"><li>Press <b>▶/■</b> on the telephone base; or</li><li>Access remotely with an access code.</li></ul>	To retrieve messages, you need an access number and/or a passcode provided by your telephone service provider.

## Set your built-in answering system

The answering system can record and store up to 99 messages. Each message can be up to three minutes in length. The total storage capacity for the announcement, messages and memos is approximately 14 minutes. The actual recording time depends on individual message characteristics.

Your answering system allows you to set your announcement, to save and delete messages, activate call screening, to set number of rings before pick up, to access remotely, and to control the recording time.

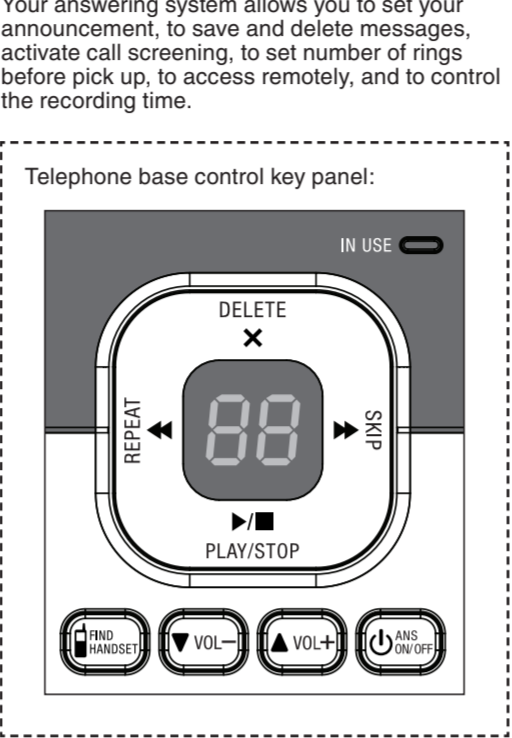

### Turn the answering system on or off

The answering system must be turned on to answer and record messages.

**To turn on or off with the telephone base:**

- Press **↓ANS ON/OFF** to turn the built-in answering system on or off.

**To turn on or off with the handset:**

- Press **MENU** when the phone is not in use.
- Scroll to **Answering sys** and then press **SELECT**.
- Scroll to **Answer on/off** and then press **SELECT**.
- Press **▼** or **▲** to choose **Answer: On** or **Answer: Off** and then press **SELECT**.

### Default announcement

The telephone is preset with a greeting that answers calls with *"Hello, please leave a message after the tone."* You can use this preset announcement, or replace it with your own.

### Record your own announcement

The announcement can be up to 90 seconds in length.

- Press **MENU** when the phone is not in use.
- Scroll to **Answering sys** then press **SELECT** twice.
- The handset announces, *"To play, press 2. To record, press 7."* Then press **7** to record.
- The handset announces, *"Record after the tone. Press 5 when you are done."* After the tone, speak towards the handset microphone.
- Press **5** or **OFF** when done.

### Play the announcement

- Press **MENU** when the phone is not in use.
- Scroll to **Answering sys** then press **SELECT** twice.
- The handset announces, *"To play, press 2. To record, press 7."* Then press **2** to play the current announcement.

Options during playback:

- Press **VOL+** or **VOL-** to adjust the listening volume.
- Press **5** or **OFF** to stop at any time.

### Delete the announcement

- Press **MENU** when the phone is not in use.
- Scroll to **Answering sys** then press **SELECT** twice.
- The handset announces, *"To play, press 2. To record, press 7."* Then press **3** to delete your own recorded announcement.

#### NOTE

- After you deleted your own recorded announcement, the answering system answers calls with the default announcement.

### Set number of rings

You can set the answering system to answer an incoming call after two, three, four, five or six rings; or toll saver. If you choose toll saver, the answering system answers a call after two rings when you have new messages, or after four rings when you have no new messages.

- Press **MENU** when the phone is not in use.
- Scroll to **Answering sys** and then press **SELECT**.
- Scroll to **Ans sys setup** and then press **SELECT**.
- Press **▶ of rings** and then press **SELECT**.
- Scroll to **▼** or **▲** to choose **6, 5, 4, 3, 2** or **Toll saver** and then press **SELECT**.

### Set recording time

You can set the recording time for each incoming message.

- Press **MENU** when the phone is not in use.
- Scroll to **Answering sys** and then press **SELECT**.
- Scroll to **Ans sys setup** and then press **SELECT**.
- Scroll to **Recording time** and then press **SELECT**.
- Press **▼** or **▲** to choose **3 minutes, 2 minutes** or **1 minute**, and then press **SELECT**.

## Use your built-in answering system

### New message indication

When there are new answering system messages, the handset displays **XX new messages**, and the message window on the telephone base flashes. When you are reviewing a new message, **NEW** displays on the handset.

If the message alert tone is turned on, the telephone base beeps every 10 seconds when there are messages that have not been reviewed.

### Message playback

#### To playback messages at the telephone base:

- Press **▶/■/PLAY** when the phone is not in use.

Options during playback:

- Press **▲VOL+** or **▼VOL-** to adjust the listening volume.
- Press **▶/SKIP** to skip to the next message.
- Press **◀REPEAT** to repeat the playing message. Press **◀REPEAT** twice to listen to the previous message.
- Press **X/DELETE** to delete the playing message. The system advances to the next message.
- Press **▶/STOP** to stop.

#### To playback messages with a handset:

- Press **MENU** when the phone is not in use, and then press **SELECT**.

Options during playback:

- Press **▲/VOLUME** or **▼/VOLUME** to adjust the listening volume.
- Press **▶** to switch between the speakerphone and the handset earpiece.
- Press **6** to skip to the next message.
- Press **4** to repeat the playing message. Press **4** twice to listen to the previous message.
- Press **3** to delete the playing message. The system advances to the next message.
- Press **OFF** to stop the playback.

#### Delete all messages

You can only delete old (reviewed) messages. You cannot delete new messages until you review them. You cannot retrieve deleted messages.

#### To delete all messages with the telephone base:

- Press **X/DELETE** twice when the phone is not in use.

#### To delete all messages with a handset:

- Press **MENU** when the phone is not in use.
- Scroll to **Answering sys** and then press **SELECT**.
- Scroll to **Delete all old** and then press **SELECT** twice.

### Remote access

A two-digit security code is required to access the answering system remotely from any touch-tone telephone. The preset code is **19**. You can use this preset code, or set your own.

- Dial your telephone number from any touch-tone telephone.
- When the system plays your announcement, enter the two-digit security code.
- Enter one of the following remote commands.

Command	Description
1	Play all messages.
2	Play only new messages.
3	Delete the current message (during playback).
33	Delete all old messages.
4	Repeat the current message (during playback).
5	Stop.
*5	Hear a list of remote commands.
6	Skip to the next message (during playback).

*7	Record a new announcement.
8	End the call.
0	Turn the answering system on or off.

- Hang up or press **8** to end the call.

### Remote access code

You can set your own remote access code from **00** to **99**.

- Press **MENU** when the phone is not in use.
- Scroll to **Answering sys** and then press **SELECT**.
- Scroll to **Ans sys setup** and then press **SELECT**.
- Scroll to **Remote code** and then press **SELECT**.
- Press the dialing keys **(0-9)** to enter the code, or **▼** or **▲** to select from **00** to **99**, then press **SELECT**.

## Use the built-in answering system and voicemail service

You can use your answering system and voicemail service together by setting your answering system to answer before voicemail service answers as described below. To learn how to program your voicemail settings, contact your telephone service provider.

If you are on a call, or if the answering system is busy recording a message and you receive another call, the second caller can leave a voicemail message.

Set your answering system to answer calls at least two rings earlier than your voicemail service is set to answer. For example, if your voicemail service answers after six rings, set your answering system to answer after four rings. Some voicemail service providers may program the delay before answering calls in seconds instead of rings. In this case, allow six seconds per ring when determining the appropriate setting.

#### NOTE

- This feature turns off the indicators only, it does not delete your voicemail messages.

- Press **MENU** when the phone is not in use.
- Scroll to **Settings** and then press **SELECT**.
- Scroll to **Cir voicemail** and then press **SELECT**.
- Press **SELECT** again to confirm.

## Retrieve voicemail from telephone service

Voicemail is a feature available from most telephone service providers. It may be included with your telephone service, or may be optional. Fees may apply.

### Retrieve voicemail

When you received a voicemail, the handset displays **☒** and **New voicemail**. To retrieve, you typically dial an access number provided by your telephone service provider, and then enter a security code. Contact your telephone service provider for instructions on how to configure the voicemail settings and listen to messages.

#### NOTE

- After you have listened to all new voicemail messages, the indicators on the handset turn off automatically.

### Set your voicemail number

You can save your access number on each handset for easy access to your voicemail.

After you saved the voicemail number, you can press and hold **☒** to retrieve voicemail.

- Press **MENU** when the phone is not in use.
- Scroll to **Settings** and then press **SELECT**.
- Scroll to **Voicemail #** and then press **SELECT**.
- Use the dialing keys to enter the voicemail number (up to 30 digits).
- Press **SELECT** to save.

### Turn off the new voicemail indicators

If you have retrieved your voicemail while away from home, and the handset still displays the new voicemail indicators, use this feature to turn off the indicators.

#### NOTE

- This feature turns off the indicators only, it does not delete your voicemail messages.

- Press **MENU** when the phone is not in use.
- Scroll to **Settings** and then press **SELECT**.
- Scroll to **Cir voicemail** and then press **SELECT**.
- Press **SELECT** again to confirm.

## Expand your telephone system

You can add new handsets (**CS6709**, purchased separately) to your telephone system. Your telephone base supports a maximum of five handsets.

For more details, refer to the user's manual that comes with your **CS6709** new handset.

## ECO mode

This power conserving technology reduces power consumption for optimal battery performance. The ECO mode activates automatically whenever the handset is synchronized with the telephone base.

## General product care

### Taking care of your telephone

Your cordless telephone contains sophisticated electronic parts, so it must be treated with care.

#### Avoid rough treatment

Place the handset down gently. Save the original packing materials to protect your telephone if you ever need to ship it.

#### Avoid water

Your telephone can be damaged if it gets wet. Do not use the handset outdoors in the rain, or handle it with wet hands. Do not install the telephone base near a sink, bathtub or shower.

#### Electrical storms

Electrical storms can sometimes cause power surges harmful to electronic equipment. For your own safety, take caution when using electrical appliances during storms.

#### Cleaning your telephone

Your telephone has a durable plastic casing that should retain its luster for many years. Clean it only with a dry non-abrasive cloth. Do not use dampened cloth or cleaning solvents of any kind.

## Frequently asked questions

Below are the questions most frequently asked about the cordless telephone. If you cannot find the answer to your question, visit our website at **www.vtechphones.com** or call **1 (800) 595-9511** for customer service.

My telephone does not work at all.	Make sure the telephone base is installed properly, and battery is installed and charged correctly. For optimum daily performance, return the handset to the telephone base after use.
The display shows <b>No line</b> . I cannot hear the dial tone.	Disconnect the telephone line cord from your telephone and connect it to another telephone. If there is no dial tone on that other telephone either, then the telephone line cord may be defective. Try installing a new telephone line cord. If changing the telephone line cord does not help, the wall jack (or the wiring to this wall jack) may be defective. Contact your telephone service provider.
The display shows <b>To register HS...</b> and <b>...see manual</b> alternately. The handset does not work at all.	You may be using a new cable or VoIP service, the existing telephone jacks in your home may no longer work. Contact your service provider for solutions. The handset is deregistered from the telephone base. Place the handset in the telephone base to register it back. The handset shows <b>Registered</b> and you hear a beep when the registration process completes. This process takes about 90 seconds to complete.

The answering system does not record messages.	Make sure the answering system is on. When the answering system is on, <b>ANS ON</b> should display on the handset and the telephone base. When the answering machine memory is full, it does not record new messages until some old messages are deleted. If you subscribe to voicemail service, change the number of rings so that your answering system answers before your voicemail service answers. To determine how many rings activate your voicemail service, contact your telephone service provider.
The answering system does not announce the correct day of the week for recorded messages time stamp.	Make sure you have set the date and time. See <b>Configure your telephone</b> section.
The messages on the answering system are incomplete.	If a caller leaves a very long message, part of it may be lost when the answering system disconnects the call after the preset recording time.
I accidentally set my LCD language to Spanish or French, and I don't know how to change it back to English.	While the handset is not in use, press <b>MENU</b> and then enter <b>X364#</b> to change the handset LCD language back to English.

## Limited warranty

### What does this limited warranty cover?

The manufacturer of this VTech Product warrants to the holder of a valid proof of purchase ("Consumer" or "you") that the Product and all accessories provided in the sales package ("Product") are free from defects in material and workmanship, pursuant to the following terms and conditions, when installed and used normally and in accordance with the Product operating instructions. This limited warranty extends only to the Consumer for Products purchased and used in the United States of America and Canada.

### What will VTech do if the Product is not free from defects in materials and workmanship during the limited warranty period ("Materially Defective Product")?

During the limited warranty period, VTech's authorized service representative will repair or replace at VTech's option, without charge, a Materially Defective Product. If we repair the Product, we may use new or refurbished replacement parts. If we choose to replace the Product, we may replace it with a new or refurbished Product of the same or similar design. We will retain defective parts, modules, or equipment. Repair or replacement of the Product, at VTech's option, is your exclusive remedy. VTech will return the repaired or replacement Products to you in working condition. You should expect the repair or replacement to take approximately 30 days.

### How long is the limited warranty period?

The limited warranty period for the Product extends for ONE (1) YEAR from the date of purchase. If VTech repairs or replaces a Materially Defective Product under the terms of this limited warranty, this limited warranty also applies to the repaired or replacement Product for a period of either (a) 90 days from the date the repaired or replacement Product is shipped to you or (b) the time remaining on the original one-year warranty; whichever is longer.

### What is not covered by this limited warranty?

This limited warranty does not cover:

- Product that has been subjected to misuse, accident, shipping or other physical damage, improper installation, abnormal operation or handling, neglect, inundation, fire, water or other liquid intrusion;
- Product that has been damaged due to repair, alteration or modification by anyone other than an authorized service representative of VTech;
- Product to the extent that the problem experienced is caused by signal conditions, network reliability, or cable or antenna systems;
- Product to the extent that the problem is caused by use with non-VTech accessories;

5. Product whose warranty/quality stickers, product serial number plates or electronic serial numbers have been removed, altered or rendered illegible;

- Product purchased, used, serviced, or shipped for repair from outside the United States of America or Canada, or used for commercial or institutional purposes (including but not limited to Products used for rental purposes);
- Product returned without a valid proof of purchase (see item 2 below); or
- Charges for installation or set up, adjustment of customer controls, and installation or repair of systems outside the unit.

### How do you get warranty service?

To obtain warranty service in the USA, please visit our website at **www.vtechphones.com** or call **1 (800) 595-9511**. In Canada, go to **www.vtechcanada.com** or call **1 (800) 267-7377**.

**NOTE:** Before calling for service, please review the user's manual - a check of the Product's controls and features may save you a service call.

Except as provided by applicable law, you assume the risk of loss or damage during transit and transportation and are responsible for delivery or handling charges incurred in the transport of the Product(s) to the service location. VTech will return repaired or replaced Product under this limited warranty. Transportation, delivery or handling charges are prepaid. VTech assumes no risk for damage or loss of the Product in transit. If the Product failure is not covered by this limited warranty, or proof of purchase does not meet the terms of this limited warranty, VTech will notify you and will request that you authorize the cost of repair prior to any further repair activity. You must pay for the cost of repair and return shipping costs for the repair of Products that are not covered by this limited warranty.

### What must you return with the Product to get warranty service?

- Return the entire original package and contents including the Product to the VTech service location along with a description of the malfunction or difficulty; and
- Include a "valid proof of purchase" (sales receipt) identifying the Product purchased (Product model) and the date of purchase or receipt; and
- Provide your name, complete and correct mailing address, and telephone number.

#### Other limitations

This warranty is the complete and exclusive agreement between you and VTech. It supersedes all other written or oral communications related to this Product. VTech provides no other warranties for this Product. The warranty exclusively describes all of VTech's responsibilities regarding the Product. There are no other express warranties. No one is authorized to make modifications to this

limited warranty and you should not rely on any such modification.

State/Provincial Law Rights: This warranty gives you specific legal rights, and you may also have other rights, which vary from state to state or province to province.

Limitations: Implied warranties, including those of fitness for a particular purpose and merchantability (an unwritten warranty that the Product is fit for ordinary use) are limited to one year from the date of purchase. Some states/provinces do not allow limitations on how long an implied warranty lasts, so the above limitation may not apply to you. In no event shall VTech be liable for any indirect, special, incidental, consequential, or similar damages (including, but not limited to lost profits or revenue, inability to use the Product or other associated equipment, the cost of substitute equipment, and claims by third parties) resulting from the use of this Product. Some states/provinces do not allow the exclusion or limitation of incidental or consequential damages, so the above limitation or exclusion may not apply to you.

### Please retain your original sales receipt as proof of purchase.

## Technical specifications

Frequency control	Crystal controlled PLL synthesizer
Transmit frequency	1921.536-1928.448 MHz
Channels	5
Nominal effective range	Maximum power allowed by FCC and IC. Actual operating range may vary according to environmental conditions at the time of use.
Power requirements	Handset: 2.4V Ni-MH battery Telephone base: 6V DC @ 400mA Charger: 6V AC @ 300mA
Memory	Directory: 50 memory locations; up to 30 digits and 15 characters Caller ID log: 50 memory locations; up to 24 digits and 15 characters



Specifications are subject to change without notice.  
© 2014 VTech Communications, Inc.  
All rights reserved. 12/14. CS6829-X\_ACIB\_V7.0  
Document order number: 91-007506-070-100

