

Go to www.vtechphones.com to register your product for enhanced warranty support and the latest VTech product news.

CS6729
 CS6729-2
 CS6729-21
 CS6729-3
 CS6729-37
 CS6729-4
 CS6729-4D
 CS6729-5

DECT 6.0 cordless telephone

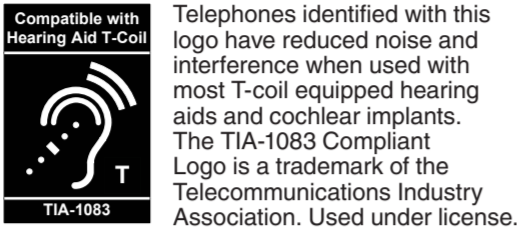

vtech

Abridged user's manual

Telephones identified with this logo have reduced noise and interference when used with most T-coil equipped hearing aids and cochlear implants. The TIA-1083 Compliant Logo is a trademark of the Telecommunications Industry Association. Used under license.

- Connect the power adapter to the telephone base and an electrical outlet not controlled by a wall switch.

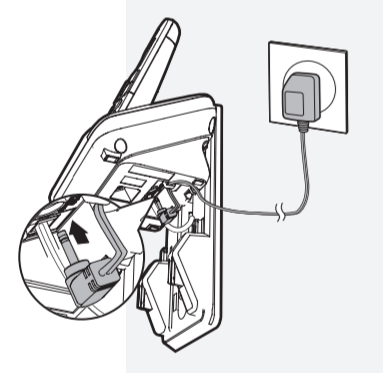

Charge the battery

Place the handset in the telephone base or the charger to charge.

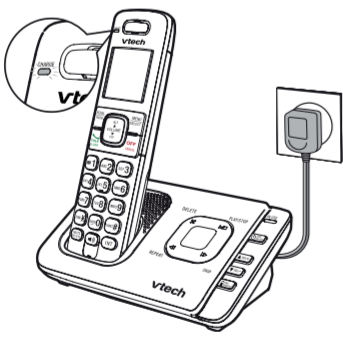

Once you have installed the battery, the handset LCD display indicates the battery status (see the table below).

NOTES

- For best performance, keep the handset in the telephone base or charger when not in use.
- The battery is fully charged after 12 hours of continuous charging.

Battery indicators	Battery status	Action
The screen is blank, or shows Put in charger and () flashes.	The battery has no charge or very little charge. The handset cannot be used.	Charge without interruption (at least 30 minutes).
The screen shows Low battery and () flashes.	The battery has enough charge to be used for a short time.	Charge without interruption (at least 30 minutes).
The screen shows HANDSET X .	The battery is charged.	To keep the battery charged, place it in the telephone base or charger when not in use.

Before use

After you install your telephone or power returns following a power outage, the handset or service menu will prompt you to set the date and time.

Set date and time

NOTE

- Make sure you set the date and time including the year correctly; otherwise the answering system does not announce the correct day of the week for your recorded messages time stamp.

- Use the dialing keys (0-9) to enter the month (MM), date (DD) and year (YY). Then press **SELECT**.
- Use the dialing keys (0-9) to enter the hour (HH) and minute (MM). Then press **▼** or **▲** to choose **AM** or **PM**.
- Press **SELECT** to save.

Check for dial tone:

Press **TALK**. If you hear a dial tone, the installation is successful.

If you do not hear a dial tone:

- Make sure the installation procedures described above are properly done.
- It may be a wiring problem. If you have changed your telephone service to digital service from a cable company or a VoIP service provider, the telephone line may need to be rewired to allow all existing telephone jacks to work. Contact your cable/VoIP service provider for more information.

Operating range

This cordless telephone operates with the maximum power allowed by the Federal Communications Commission (FCC). Even so, this handset and telephone base can communicate over only a certain distance - which can vary with the locations of the telephone base and handset, the weather, and the layout of your home or office.

When the handset is out of range, the handset displays **Out of range** or **no pwr at base**.

If there is a call while the handset is out of range, it may not ring, or if it does ring, the call may not connect well when you press **TALK**. Move closer to the telephone base, and then press **TALK** to answer the call. If the handset moves out of range during a telephone conversation, there may be interference. To improve reception, move closer to the telephone base.

What's in the box

Your product package contains the following items. Save your sales receipt and original packaging in the event warranty service is necessary.

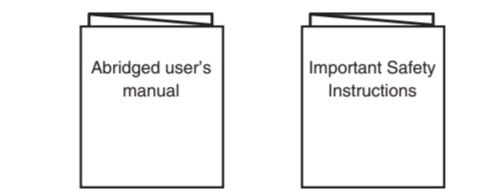
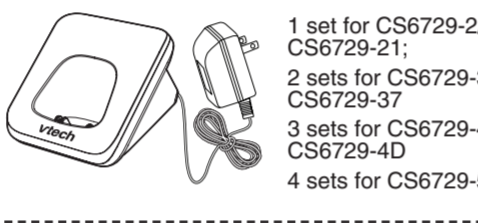
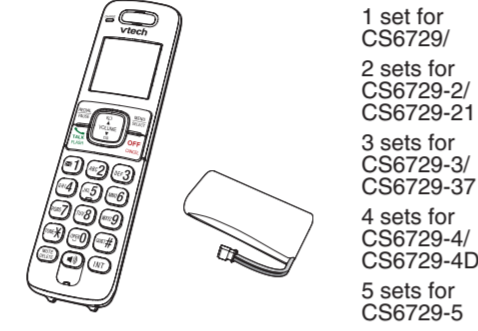
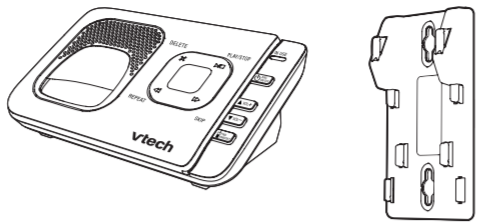

- 1 set for CS6729/
- 2 sets for CS6729-2/CS6729-21
- 3 sets for CS6729-3/CS6729-37
- 4 sets for CS6729-4/CS6729-4D
- 5 sets for CS6729-5

- 1 set for CS6729-2/CS6729-21;
- 2 sets for CS6729-3/CS6729-37
- 3 sets for CS6729-4/CS6729-4D
- 4 sets for CS6729-5

Handset overview

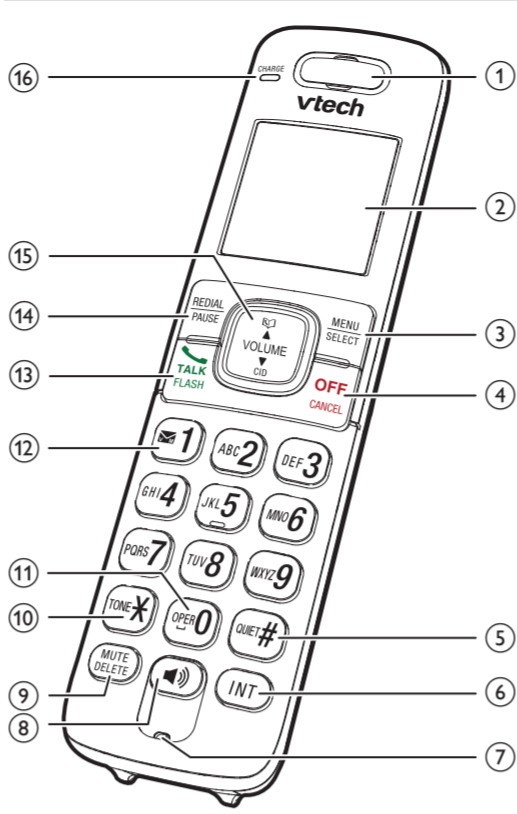

- 1 - **Handset earpiece**
- 2 - **LCD display**
- 3 - **MENU/SELECT**
 - Show the menu.
 - While in a menu, press to select an item, or save an entry or setting.
- 4 - **OFF/CANCEL**
 - Hang up a call.
 - Silence the ringer temporarily while the handset is ringing.
 - Press and hold to erase the missed call indicator while the phone is not in use.
 - Press to return to the previous menu; or press and hold to return to idle mode, without making changes.
- 5 - **OPER#**
 - Press repeatedly to show other dialing options when reviewing a caller ID log entry.
- 6 - **INT**
 - Press to start an intercom conversation or transfer a call (for multi-handset models only).

7 - Microphone

- Make or answer a call using the handset speakerphone.
- During a call, press to switch between the speakerphone and the handset.

9 - MUTE/DELETE

- Mute the microphone during a call.
- Delete digits or characters while using the dialing keys.
- Silence the ringer temporarily while the handset is ringing.

10 - TONE X

- While you have set the dial mode to pulse and on a call, press to switch to tone dialing temporarily.

11 - OPER 0

- Press to add a space when entering names.

12 - 1

- Press repeatedly to add or remove 1 in front of the caller ID log entry before dialing or saving it to the directory.
- Press and hold to set or dial your voicemail number.

13 - TALK/FLASH

- Make or answer a home call.
- Answer an incoming home call when you hear a call waiting alert.

14 - REDIAL/PAUSE

- Review the directory when the phone is not in use.
- Press and hold to insert a dialing pause while entering a number.

15 - VOLUME/▲/▼

- Review the directory when the phone is not in use.
- Increase the listening volume during a call.
- Scroll up while in a menu, or in the directory, caller ID log, or redial list.
- Move the cursor to the right when entering numbers or names.

VOLUME/▼/CID

- Review the caller ID log when the phone is not in use.
- Decrease the listening volume during a call.
- Scroll down while in a menu, or in the directory, caller ID log, or redial list.
- Move the cursor to the left when entering numbers or names.

16 - CHARGE light

- On when the handset is charging.

Telephone base overview

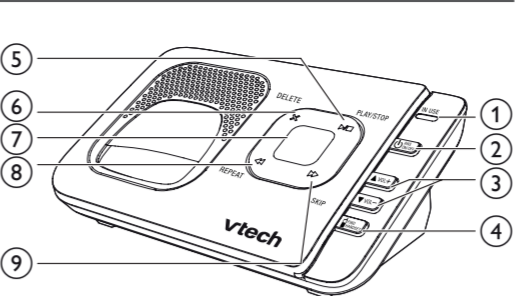

1 - IN USE light

- Flashes when there is an incoming call, or another telephone sharing the same line is in use.
- Flashes when handsets are being deregistered.
- On when the handset is in use or being registered.
- On when the answering system is answering a call.

2 - ANSWERS ON/OFF

- Press to turn the answering system on or off.

3 - ▲VOL+ and ▼VOL-

- Press to adjust the volume during message playback.
- When the phone is not in use, press to adjust the telephone base ringer volume.

4 - /FIND HANDSET

- Press to page all system handsets.

5 - ►/PLAY/STOP

- Press to play messages.
- Press to stop message

6 - X/DELETE

- Press to delete the playing message.
- When the phone is not in use, press twice to delete all previously reviewed messages.

7 - Message window

- Shows the number of messages, and other information of the answering system or telephone base.

8 - ◀/REPEAT

- Press to repeat the playing message.
- Press twice to play the previous message.

9 - ►/SKIP

- Press to skip to the next message.

Charger overview

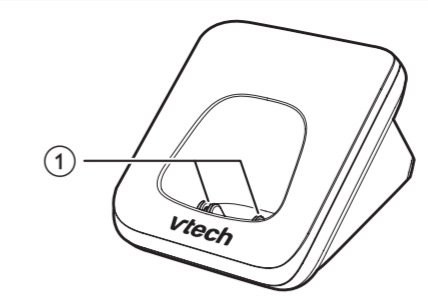

1 - Charging pole

Display icons overview

	The battery icon flashes when the battery is low and needs charging.
	The battery icon animates when the battery is charging.
	The battery icon becomes solid when the battery is fully charged.
	The handset ringer is off.
	There are new voicemail received from your telephone service provider.
	The message number currently playing and total number of new/old messages recorded.
	The answering system is turned on.
	The ECO mode activates automatically to reduce power consumption when the handset is within range from the telephone base.
	There are new caller ID log entries.

Connect

You can choose to connect the telephone base for desktop usage or wall mounting.

NOTE

- Use only the power adapters supplied with this product.

TIP

- If you subscribe to digital subscriber line (DSL) high-speed Internet service through your telephone line, make sure you install a **DSL filter** (not included) between the telephone line cord and telephone wall jack. Contact your DSL service provider for more information.

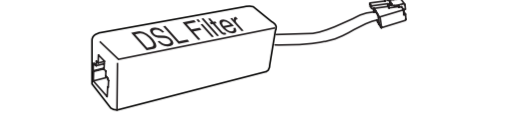

Connect the telephone base

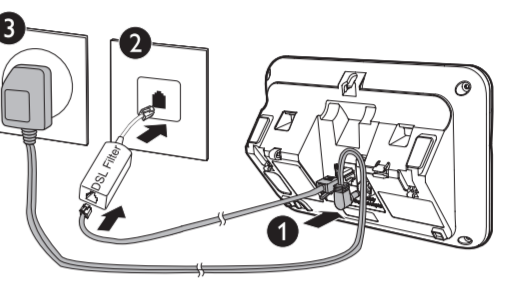

Connect the charger

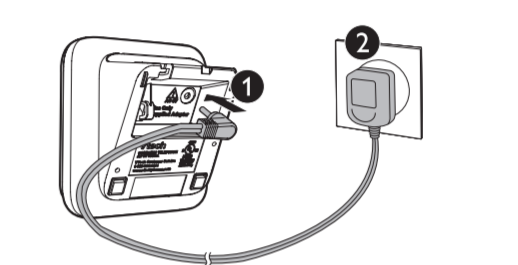

Mount the telephone base

The telephone comes ready for tabletop use. If you have already installed the telephone for tabletop use, unplug the telephone line cord from the telephone wall jack, and unplug the telephone base power adapter from the wall outlet before mounting your telephone on a wall. Follow the steps below to mount your telephone on a wall.

- Route the telephone line cord through the rectangular hole on the wall mount bracket.

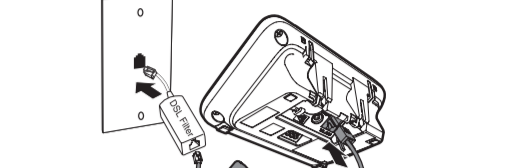

- Align the holes on the bracket with the standard wall plate and slide the bracket down until it clicks securely in place.

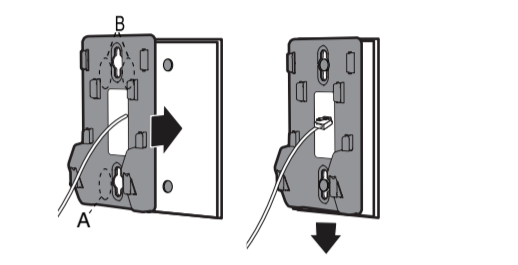

- Align the grooves on the telephone base with the tabs on the wall mount bracket, and then slide it down until it clicks securely in place.

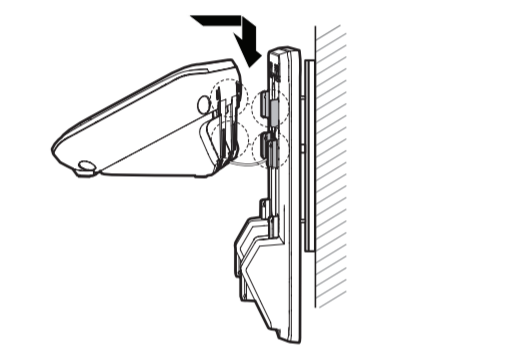

- Connect the power adapter to the telephone base and an electrical outlet not controlled by a wall switch.

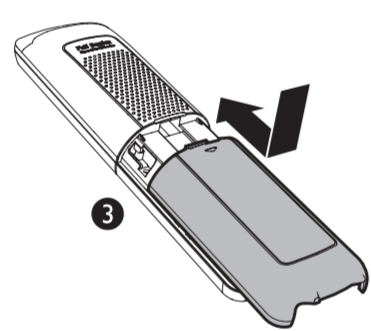

Charge the battery

Place the handset in the telephone base or the charger to charge.

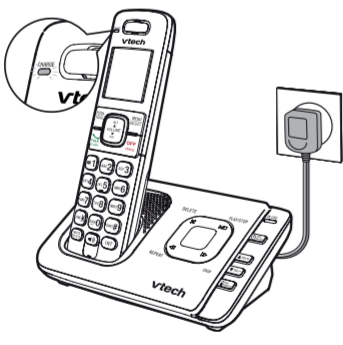

Once you have installed the battery, the handset LCD display indicates the battery status (see the table below).

NOTES

- For best performance, keep the handset in the telephone base or charger when not in use.
- The battery is fully charged after 12 hours of continuous charging.

Battery indicators	Battery status	Action
The screen is blank, or shows Put in charger and () flashes.	The battery has no charge or very little charge. The handset cannot be used.	Charge without interruption (at least 30 minutes).
The screen shows Low battery and () flashes.	The battery has enough charge to be used for a short time.	Charge without interruption (at least 30 minutes).
The screen shows HANDSET X .	The battery is charged.	To keep the battery charged, place it in the telephone base or charger when not in use.

Before use

After you install your telephone or power returns following a power outage, the handset or service menu will prompt you to set the date and time.

Set date and time

NOTE

- Make sure you set the date and time including the year correctly; otherwise the answering system does not announce the correct day of the week for your recorded messages time stamp.

- Use the dialing keys (0-9) to enter the month (MM), date (DD) and year (YY). Then press **SELECT**.
- Use the dialing keys (0-9) to enter the hour (HH) and minute (MM). Then press **▼** or **▲** to choose **AM** or **PM**.
- Press **SELECT** to save.

Check for dial tone:

Press **TALK**. If you hear a dial tone, the installation is successful.

If you do not hear a dial tone:

- Make sure the installation procedures described above are properly done.
- It may be a wiring problem. If you have changed your telephone service to digital service from a cable company or a VoIP service provider, the telephone line may need to be rewired to allow all existing telephone jacks to work. Contact your cable/VoIP service provider for more information.

Operating range

This cordless telephone operates with the maximum power allowed by the Federal Communications Commission (FCC). Even so, this handset and telephone base can communicate over only a certain distance - which can vary with the locations of the telephone base and handset, the weather, and the layout of your home or office.

When the handset is out of range, the handset displays **Out of range** or **no pwr at base**.

If there is a call while the handset is out of range, it may not ring, or if it does ring, the call may not connect well when you press **TALK**. Move closer to the telephone base, and then press **TALK** to answer the call. If the handset moves out of range during a telephone conversation, there may be interference. To improve reception, move closer to the telephone base.

Using the handset menu

- Press **MENU** when the phone is not in use.
- Press **▼** or **▲** until the screen displays the desired feature menu.
- Press **SELECT** to enter that menu.
- To return to the previous menu, press **CANCEL**.
- To return to idle mode, press and hold **CANCEL**.

Configure your telephone

Set language

The LCD language is preset to English. You can select English, French or Spanish to be used in all screen displays.

- Press **MENU** when the handset is not in use.
- Scroll to **Settings**, and then press **SELECT** twice.
- Scroll to choose **English**, **Français** or **Español**, and then press **SELECT**.
- Press **SELECT** again to save.

Set date and time

NOTE

Make sure you set the date and time including the year correctly; otherwise the answering system does not announce the correct day of the week for your recorded messages time stamp.

- Press **MENU** when the handset is not in use.
- Scroll to **Set date/time**, and then press **SELECT**.
- Use the dialing keys (0-9) to enter the month (MM), date (DD) and year (YY). Then press **SELECT**.
- Use the dialing keys (0-9) to enter the hour (HH) and minute (MM). Then press **▼** or **▲** to choose **AM** or **PM**.
- Press **SELECT** to save.

Temporary tone dialing

If you have pulse (rotary) service only, you can switch from pulse to tone dialing temporarily during a call.

- During a call, press **TONE X**.
- Use the dialing keys to enter the relevant number. The telephone sends touch-tone signals. It automatically returns to pulse dialing mode after you end the call.

Telephone operation

Handset control key panel:



Make a call

- Press **TALK** or **FLASH**, and then dial the telephone number.

Answer a call

- Press **TALK**, **FLASH**, or any dialing key.

End a call

- Press **OFF** on the handset, or put the handset to the base or charger.

Speakerphone

- During a call, press **FLASH** on the handset to switch between speakerphone and normal handset use.

Volume

- During a call, press **VOLUME/▲** on the handset to adjust the listening volume.

NOTE

- The handset earpiece volume setting and speakerphone volume setting are independent.

Mute

The mute function allows you to hear the other party but the other party cannot hear you.

- During a call, press **MUTE** on the handset or telephone base. The screen displays **Muted**.
- Press **MUTE** again to resume the conversation. The screen displays **Microphone ON**.

Call waiting

When you subscribe to call waiting service from your telephone service provider, you hear an alert tone if there is an incoming call while you are on another call.

- Press **FLASH** to put the current call on hold and take the new call.
- Press **FLASH** to switch back and forth between calls.

Find handset

Use this feature to find all system handsets.

To start paging:

- Press **FIND HANDSET** on the telephone base. All idle handsets ring and display **** Paging ****.

To end paging:

- Press **FIND HANDSET** again on the telephone base.

-OR-

- Press **TALK**, **FLASH**, **OFF**, or any dialing key on the handset.

-OR-

- Place the handset in the telephone base or charger.

NOTE

- Do not press and hold **FIND HANDSET** for more than four seconds. It may lead to handset deregistration.

Join a call in progress

You can use up to two system handsets at a time on a home line call. You can buy additional expansion handsets (CS6709) for this telephone base. You can register up to five handsets to the telephone base.

- When a handset is on a home call, press **TALK** or **FLASH** on another handset to join the call.
- Press **OFF** to exit the call. The call continues until all handsets hang up.

Transfer a call

While on an outside call, you can transfer the call from one handset to another.

- Press **MENU** on your handset during a call.
- Scroll to **Transfer**, and then press **SELECT**.
- Use the dialing keys to enter a destination handset number.
- To answer the intercom call, press **TALK**, **FLASH**, or any dialing key on the destination handset.

###

- Press **SELECT** twice. The screen displays **Reassign SD**.
- Press **SELECT**. The screen displays **Copy from DIR...** and then the first entry of the directory.
- Scroll to browse to the desired entry.
 - OR-**
- Use the alphabetical search to find the desired entry.
- Press **SELECT** to save. You hear a confirmation. The name (up to 12 characters) appears in the selected speed dial location.

Dial a speed dial number

- Press and hold a dialing key (0 or 2-9) to dial the number stored in the corresponding speed dial location.

When the speed dial location is empty, the screen displays the speed dial list. See **Assign a speed dial entry** to add a new entry.

Delete a speed dial entry

- Press **MENU** when the phone is not in use.
- Scroll to **Directory**, then press **SELECT**.
- Scroll to **Speed dial**, then press **SELECT**.
- Press **▼** or **▲**, or use the dialing keys to choose the desired speed dial location, then press **DELETE**. The screen displays **Clear SD #X?**
- Press **SELECT** to confirm. You hear a confirmation tone.

NOTE

Deleting the speed dial entries does not affect the entries in the directory.

Caller ID

If you subscribe to caller ID service, information about each caller appears after the first or second ring. If you answer a call before the caller information appears on the screen, it will not be saved in the caller ID log.

The caller ID log stores up to 50 entries. Each entry has up to 24 digits for the phone number and 15 characters for the name.

If the telephone number has more than 15 digits, only the last 15 digits appear. If the name has more than 15 characters, only the first 15 characters are shown and saved in the caller ID log.

Review a caller ID log entry

- Press **CID** when the phone is not in use.
- Scroll to browse through the caller ID log. When the desired entry appears:
 - Press **#** repeatedly to show different dialing options.
 - Press 1 repeatedly if you need to add or remove 1 in front of the phone number.
 - Press ↶ or ↷ to dial the displayed number.

Dial a caller ID log entry

- When the desired entry appears, press ↶ or ↷ to dial.

Save a caller ID log entry to the directory

- When the desired caller ID log entry displays, press **SELECT**.
- Scroll to **To Directory** then press **SELECT**.
- Use the dialing keys to modify the number, and then press **SELECT**.
- Use the dialing keys to modify the name, and then press **SELECT** to save.

Delete a caller ID log entry

- When the desired caller ID log entry displays, press **DELETE**.

Delete all caller ID log entries

- Press **MENU** when the phone is not in use. Scroll to **Caller ID log** and then press **SELECT**. Scroll to **Dial all calls** and then press **SELECT** twice.

Sound settings

Key tone

You can choose from different ringer tones.

- Press **MENU** when the handset is not in use.
- Scroll to **Settings**, and then press **SELECT**.
- Scroll to choose **Key tone**, and then press **SELECT**.
- Scroll to choose **On** or **Off**, and then press **SELECT** to save.

Ringer tone

You can choose from different ringer tones.

- Press **MENU** when the handset is not in use.
- Scroll to **Ringers**, and then press **SELECT**.
- Scroll to choose **Ringer tone**, and then press **SELECT**.
- Scroll to **sample each ringer tone**, and then press **SELECT** to save.

NOTE

- If you turn off the ringer volume, you will not hear ringer tone samples.

Ringer volume

You can adjust the ringer volume level, or turn the ringer off.

- Press **MENU** when the handset is not in use.
- Scroll to **Ringers**, and then press **SELECT**.
- Press **SELECT** to choose **Ringer volume**.
- Scroll to **adjust the volume**, and then press **SELECT** to save.

NOTE

- If the handset ringer volume is set to off, that handset is silenced for all incoming calls except paging tone.

Ringer volume (telephone base)

You can adjust the telephone base volume level by pressing **▼VOL-** or **▲VOL+** on the top of the telephone base when idle.

Temporary ringer silencing

When the telephone is ringing, you can temporarily silence the ringer of the handset without disconnecting the call. The next call rings normally at the preset volume.

- Press **OFF** or **MUTE** on the handset. The handset displays ⏻ and **Ringer muted** briefly.

Quiet mode

You can turn on the quiet mode for a period of time. During this period, all tones (except paging tone) and call screening are muted. When you turn on the quiet mode, the answering system turns on automatically.

- Press and hold ⏻**#** on the handset or telephone base when idle.
- Use the dialing keys (0-9) to enter the duration, and then press **SELECT** to save.

- To turn off the quiet mode, press and hold ⏻**#** on the handset or telephone base when idle.

About answering system and voicemail service

For message recording, your telephone has a built-in answering system, and it also support voicemail service offered by your telephone service provider (subscription is required, and fee may apply).

The main differences between them are as follows:

Category	Built-in answering system	Voicemail from telephone service
Storage	Messages are stored in the telephone base.	Messages are stored in a server or system provided by your telephone service.
	Your messages will not be deleted automatically. You have to delete your messages manually.	Your messages may be automatically deleted after a period of time. Contact your telephone service provider for more details.
Method to retrieve messages	When you received new messages, handset displays XX new messages and the message window on the telephone base flashes.	When you received new messages, the handset displays ✉ and New voicemail .
	To retrieve messages, usually there are two ways: <ul style="list-style-type: none">Press a button on the telephone base, or Access remotely with an access code.	To retrieve messages, you need an access number and/or a passcode provided by your telephone service provider.

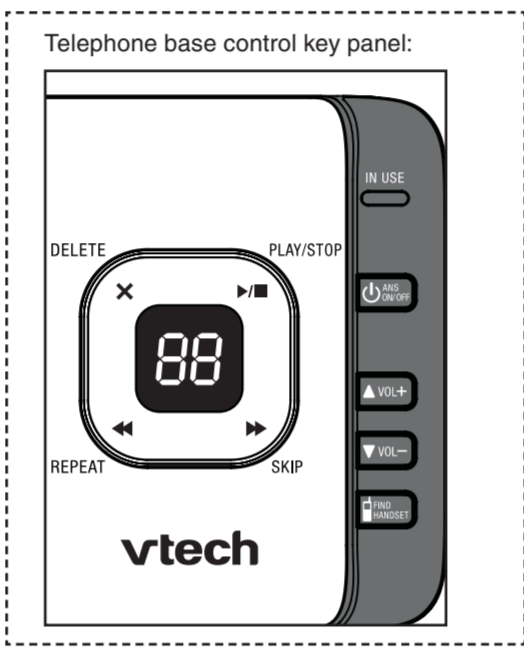

Set your built-in answering system

Your answering system has various features, read below for the basic settings.

The answering system can record and store up to 99 messages. Each message can be up to three minutes in length. The total storage capacity for the announcement, messages and memos is approximately 14 minutes. The actual recording time depends on individual message characteristics.

Your answering system allows you to set your announcement, to save and delete messages, activate call screening, to set number of rings before pick up, to access remotely, and to control the recording time.

Turn the answering system on or off

The answering system must be turned on to answer and record messages.

To turn on or off with the telephone base:

- Press ⏻**ANS ON** on the telephone base to turn the built-in answering system on or off.

To turn on or off with the handset:

- Press **MENU** when the phone is not in use.
- Scroll to highlight **Answering sys**, and then press **SELECT**.
- Scroll to highlight **Answer on/off**, and then press **SELECT**.
- Scroll to highlight **Answer: On** or **Answer: Off**, and then press **SELECT** to save. You hear a confirmation tone.

Default announcement

The telephone is preset with a greeting that answers calls with "Hello, please leave a message after the tone." You can use this preset announcement, or replace it with your own.

Record your own announcement

The announcement can be up to 90 seconds in length.

- Press **MENU** when the phone is not in use.
- Scroll to **Answering sys** and then press **SELECT** twice.
- The handset displays **Play [2] Del [3] Rec [7]**, and it announces, *"To play, press 2. To record, press 7."*
- Press **7** to record. The handset announces, *"Record after the tone. Press 5 when you are done."* After the tone, speak towards the handset microphone. Then, press **5** when done.

Play the announcement

- Press **MENU** when the phone is not in use.
- Scroll to **Answering sys** and then press **SELECT** twice.
- The handset displays **Play [2] Del [3] Rec [7]**, and it announces, *"To play, press 2. To record, press 7."*
- Press **2** to play the announcement.

Delete the announcement

- Press **MENU** when the phone is not in use.
- Scroll to **Answering sys** and then press **SELECT** twice.
- The handset displays **Play [2] Del [3] Rec [7]**, and it announces, *"To play, press 2. To record, press 7."*
- Press **3** to delete your own recorded announcement.

Set number of rings

You can set the answering system to answer an incoming call after 2, 3, 4, 5 or 6 rings; or toll saver. If you choose toll saver, the answering system answers a call after 2 rings when you have new messages, or after 4 rings when you have no new messages.

- Press **MENU** when the phone is not in use.
- Scroll to highlight **Answering sys**, and then press **SELECT**.
- Scroll to highlight **Answer on/off**, and then press **SELECT**.
- Scroll to **# of rings** then press **SELECT**.
- Scroll to choose **2, 3, 4, 5, 6** or **Toll saver**.
- Press **SELECT** to save and you hear a confirmation tone.

Message alert tone

When the message alert tone is set to on, and there is at least one new message, the telephone base beeps every 10 seconds. The message alert tone is preset to off.

- Press **MENU** when the phone is not in use.
- Scroll to **Answering sys** then press **SELECT**.
- Scroll to **Ans sys setup** then press **SELECT**.
- Scroll to **Msg alert tone** then press **SELECT**.
- Scroll to choose **Tone: On** or **Tone: Off**.
- Press **SELECT** to save and you hear a confirmation tone.

Recording time

You can set the recording time limit for each incoming message.

- Press **MENU** when the phone is not in use.
- Scroll to **Answering sys** then press **SELECT**.
- Scroll to **Ans sys setup** then press **SELECT**.
- Scroll to **Recording time** then press **SELECT**.
- Scroll to choose **3 minutes, 2 minutes** or **1 minute**.
- Press **SELECT** to save and you hear a confirmation tone.

Use your built-in answering system

New message indication

When there are new answering system messages, The handset displays **XX new messages** and the message window on the telephone base flashes.

Message playback

- To playback messages at the telephone base:**
 - Press ▶**/▶PLAY** when the phone is not in use.

Options during playback:

- Press ▼**VOL-** or ▲**VOL+** to adjust the speaker volume.
- Press ⏻**/SKIP** to skip to the next message.
- Press ⏻**/REPEAT** to repeat the message currently playing. Press ⏻**/REPEAT** twice to listen to the previous message.
- Press **X/DELETE** to delete the playing message. The system advances to the next message.
- Press ▶**/▶STOP** to stop.

To playback messages at the handset:

- Press **MENU** to choose **Play messages**. Press **SELECT**.

Options during playback:

- Press ◀**/VOLUME/▲** to adjust the message playback volume.
- Press **6** to skip to the next message.
- Press **4** to repeat the message. Press **4** during the time and day announcement to hear the previous message.
- Press **3** to delete the playing message.
- Press **OFF** to stop the playback.
- Press ↶ to switch between speakerphone mode and handset mode.

Delete all old messages at the telephone base

To delete all old messages at the telephone base:

Press **X/DELETE** twice when the phone is not in use.

To delete all old messages on a handset:

- Press **MENU** when the phone is not in use.
- Scroll to **Answering sys**, and then press **SELECT**.
- Scroll to **Delete all old**, and then press **SELECT** twice. You hear a confirmation tone.

Remote access

A two-digit security code is required to access the answering system remotely from any touch-tone telephone. The preset code is **19**. You can use this preset code, or set your own.

- Dial your telephone number from any touch-tone telephone.
- When the system plays your announcement, enter the two-digit security code.
- You can enter one of the following remote commands.

Command	Description
1	Play all messages.
2	Play new messages.
3	Delete the current message (during playback).
33	Delete all old messages.
4	Repeat the current message (during playback).
5	Stop.
*5	Hear a list of remote commands.
6	Skip to the next message (during playback).
*7	Record a new announcement.
8	End the call.
0	Turn the answering system on or off.

- Hang up or press **8** to end the call.

Remote access code

A two-digit security code is required to access the answering system remotely from any touch-tone telephone. The preset code is **19**. You can set the code from **00** to **99**.

- Press **MENU** when the phone is not in use.
- Scroll to **Answering sys** then press **SELECT**.
- Scroll to **Ans sys setup** then press **SELECT**.
- Scroll to **Remote code**, and then press **SELECT**.
- Use the dialing keys to enter a two-digit number.
 - OR-**
- Press **SELECT** to save and you hear a confirmation tone.

Use the built-in answering system and voicemail service

You can use your answering system and voicemail service together by setting your answering system to answer before voicemail service answers as described below. To learn how to program your voicemail settings, contact your telephone service provider.

If you are on a call, or if the answering system is busy recording a message and you receive another call, the second caller can leave a voicemail message.

Set your answering system to answer calls at least two rings earlier than your voicemail service is set to answer. For example, if your voicemail service answers after six rings, set your answering system to answer after four rings. Some voicemail service providers may program the delay before answering calls in seconds instead of rings. In this case, allow six seconds per ring when determining the appropriate setting.

Retrieve voicemail from telephone service

Voicemail is a feature available from most telephone service providers. It may be included with your telephone service, or may be optional. Fees may apply.

Retrieve voicemail

When you received a voicemail, the handset displays ✉ and **New voicemail**. To retrieve, you typically dial an access number provided by your telephone service provider, and then enter a security code. Contact your telephone service provider for instructions on how to configure the voicemail settings and listen to messages.

Turn off the new voicemail indicators

If you have retrieved your voicemail while away from home, and the handset still displays the new voicemail indicators, use this feature to turn off the indicators.

NOTE

- This feature turns off the indicators only, it does not delete your voicemail messages.

- Press **MENU** when the handset is not in use.
- Scroll to **Settings**, and then press **SELECT**.
- Scroll to **Cir voicemail**, and then press **SELECT**.
- Press **SELECT** to save and you hear a confirmation tone.

Expand your telephone system

You can add new handsets (**CS6709**, purchased separately) to your telephone system. Your telephone base supports a maximum of five handsets.

For more details, refer to the user's manual that comes with your **CS6709** new handset.

ECO mode

This power conserving technology reduces power consumption for optimal battery performance. The ECO mode activates automatically whenever the handset is synchronized with the telephone base.

General product care

Taking care of your telephone

Your cordless telephone contains sophisticated electronic parts, so it must be treated with care.

Avoid rough treatment

Place the handset down gently. Save the original packing materials to protect your telephone if you ever need to ship it.

Avoid water

Your telephone can be damaged if it gets wet. Do not use the handset outdoors in the rain, or handle it with wet hands. Do not install the telephone base near a sink, bathtub or shower.

Electrical storms

Electrical storms can sometimes cause power surges harmful to electronic equipment. For your own safety, take caution when using electrical appliances during storms.

Cleaning your telephone

Your telephone has a durable plastic casing that should retain its luster for many years. Clean it only with a dry non-abrasive cloth. Do not use dampened cloth or cleaning solvents of any kind.

Frequently asked questions

Below are the questions most frequently asked about the cordless telephone. If you cannot find the answer to your question, visit our website at

www.vtechphones.com or call **1 (800) 595-9511** for customer service. In Canada, go to **www.vtechcanada.com** or call **1 (800) 267-7377**.

My telephone does not work at all.	Make sure the telephone base is installed properly, and battery is installed and charged correctly. For optimum daily performance, return the handset to the telephone base after use.
------------------------------------	--

The display shows No line . I cannot hear the dial tone.	Disconnect the telephone line cord from your telephone and connect it to another telephone. If there is no dial tone on that other telephone either, then the telephone line cord may be defective. Try installing a new telephone line cord. If changing telephone line cord does not help, the wall jack (or the wiring to this wall jack) may be defective. Contact your telephone service provider. You may be using a new cable or VoIP service, the existing telephone jacks in your home may no longer work. Contact your service provider for solutions.
---	--

The display shows To register HS... and ...see manual alternately. The handset does not work at all.	The handset is deregistered from the telephone base. Place the handset in the telephone base to register it back. The handset shows Registered and you hear a beep when the registration process completes. This process takes about 90 seconds to complete.
--	---

The answering system does not record messages.	Make sure the answering system is on. When the answering system is on, ANS ON should display on the handset and the telephone base.
--	--

	When the answering machine memory is full, it does not record new messages until some old messages are deleted.
--	---

	If you subscribe to voicemail service, change the number of rings so that your answering system answers before your voicemail service answers. To determine how many rings activate your voicemail service, contact your telephone service provider.
--	--

The answering system does not announce the correct day of the week for recorded messages time stamp.	Make sure you have set the date and time. See Configure your telephone section.
--	--

The messages on the answering system are incomplete.	If a caller leaves a very long message, part of it may be lost when the answering system disconnects the call after the preset recording time.
	If the memory on the answering system becomes full during a message, the answering system stops recording and disconnects the call.
I accidentally set my LCD language to Spanish or French, and I don't know how to change it back to English.	While the handset is not in use, press MENU and then enter *364# to change the handset LCD language back to English.

Limited warranty

What does this limited warranty cover?

The manufacturer of this VTech Product warrants to the holder of a valid proof of purchase ("Consumer" or "you") that the Product and all accessories provided in the sales package ("Product") are free from defects in material and workmanship, pursuant to the following terms and conditions, when installed and used normally and in accordance with the Product operating instructions. This limited warranty extends only to the Consumer for Products purchased and used in the United States of America and Canada.

What will VTech do if the Product is not free from defects in materials and workmanship during the limited warranty period ("Materially Defective Product")?

During the limited warranty period, VTech's authorized service representative will repair or replace at VTech's option, without charge, a Materially Defective Product. If we repair the Product, we may use new or refurbished replacement parts. If we choose to replace the Product, we may replace it with a new or refurbished Product of the same or similar design. We will retain defective parts, modules, or equipment. Repair or replacement of the Product, at VTech's option, is your exclusive remedy. VTech will return the repaired or replacement Products to you in working condition. You should expect the repair or replacement to take approximately 30 days.

How long is the limited warranty period?

The limited warranty period for the Product extends for ONE (1) YEAR from the date of purchase. If VTech repairs or replaces a Materially Defective Product under the terms of this limited warranty, this limited warranty also applies to the repaired or replacement Product for a period of either (a) 90 days from the

date the repaired or replacement Product is shipped to you or (b) the time remaining on the original one-year warranty, whichever is longer.

What is not covered by this limited warranty?

This limited warranty does not cover:

- Product that has been subjected to misuse, accident, shipping or other physical damage, improper installation, abnormal operation or handling, neglect, inundation, fire, water or other liquid intrusion; or
- Product that has been damaged due to repair, alteration or modification by anyone other than an authorized service representative of VTech; or
- Product to the extent that the problem experienced is caused by signal conditions, network reliability, or cable or antenna systems; or
- Product to the extent that the problem is caused by use with non-VTech accessories; or
- Product whose warranty/quality stickers, product serial number plates or electronic serial numbers have been removed, altered or rendered illegible; or
- Product purchased, used, serviced, or shipped for repair from outside the United States of America or Canada, or used for commercial or institutional purposes (including but not limited to Products used for rental purposes); or
- Product returned without a valid proof of purchase (see item 2 on the next page); or
- Charges for installation or set up, adjustment of customer controls, and installation or repair of systems outside the unit.

How do you get warranty service?

To obtain warranty service in the United States of America, please visit our website at **www.vtechphones.com** or call **1 (800) 595-9511**. In Canada, go to **www.vtechcanada.com** or dial **1 (800) 267-7377**.